



Transport & logistics



Always a solution!

Always a solution

CARU Containers operates as European market leader in sales, rentals and leasing of new and used containers. Our customers can be found in different industries, like shipping, off-shore, logistics, construction, automotive, oil- and chemical industry, general industry, governments, municipalities, army, traders and rental companies.



Container solutions that support your logistical services

You want to be able to quickly have containers available for your services? Anywhere in the world? At any moment? In any size? CARU Containers has the solution for you!

Thanks to our global network of depots and an excellent maritime network, we can supply complete container solutions! We constantly invest in the improvement of our existing containers and the development of new ones, so we're able to deliver you the best service and quality.

From standard containers, to reefers, tanks and specials, like: open top, hard top, flats and many more. We are able to supply just what you need. This makes it easy for you and due to the short delivery time, you get value for money.

How our solutions can benefit you:

- New and used containers are always available, so you can be certain that you always get the quality you want
- Rental and leasing is possible for long and short term, so you can always choose the most cost-effective solution
- Modified and rebuilt containers are possible, giving you the ability to transport rare and special products
- Maintenance and repair services are offered, giving you the certainty that your product will always be in top condition
- Our optional Buy-back guarantee gives you the certainty that you will be able to sell the containers after you're finished with them
- Our Lease-purchase option gives you the freedom to pay on your terms

CARU Containers: Always a solution!



All containers in this brochure are:

- Available for sale and rental
- Available as new and used containers
- Standard with wooden floor
- Provided with CSC certificate
- Suitable for transport and storage

Maximum payload depends on the weight of the container.
Given weights are guidelines.

For exact weights you can contact one of our offices.

For more information, check www.carucontainers.com

20ft Container ISO Dimensions

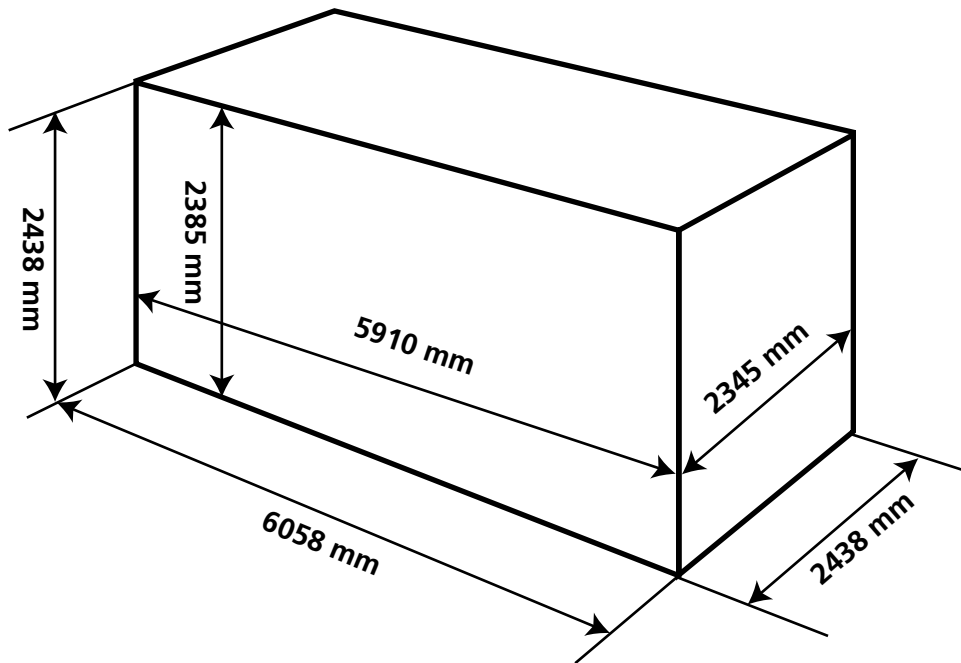

40ft Container ISO Dimensions

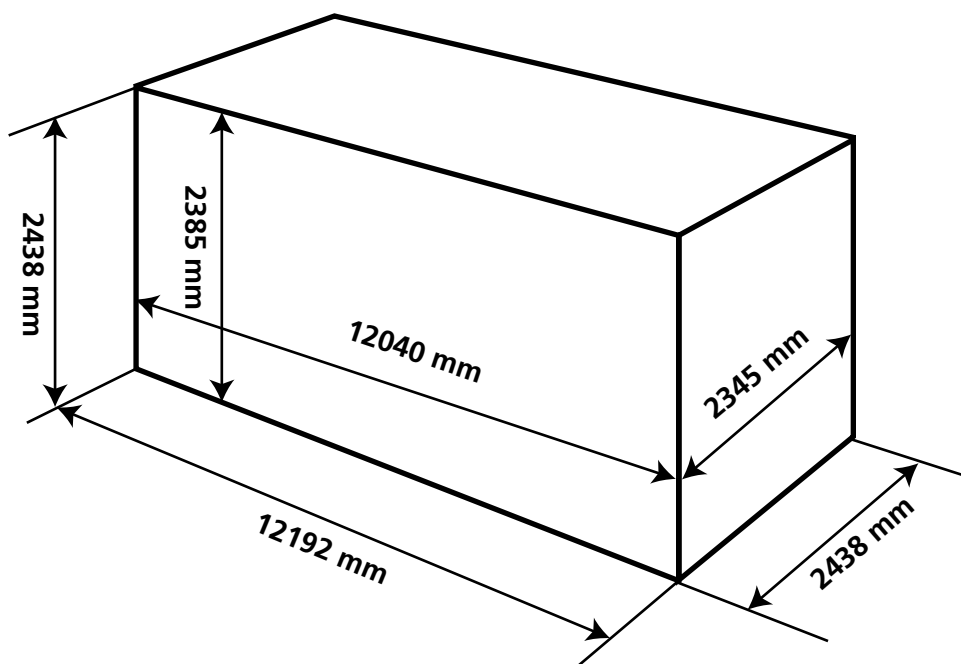

We offer various container solutions



20ft & 40ft Standard Containers

- Modifications are possible to meet your requirements, for instance: racks, painting, labeling, assembling systems, etc.
- Can be modified to different sizes
- Used 20ft & 40ft standard containers are available in three different classes



20ft & 40ft High Cube Containers

- Containers are 30 cm higher than standard containers, so you can transport voluminous cargo
- Modifications are possible to meet your requirements, for instance: Racks, painting, labeling, assembling of systems, etc.
- Can be modified to different sizes



20ft Reefer Domestic

- Meets HACCP requirements
- 24/7 repair service, in the Netherlands and Belgium
- Before delivery, these containers are tested (Pre Trip Inspection, machine gets tested for 24 hours to discover any malfunctions)



20ft Reefer Domestic

- Cooling installation with low noise level (Zanotti), for use within urban areas or shopping malls
- Includes: Panic Lock; inside lightning and anti slip floor

We offer various container solutions



20ft & 40ft Open Top Original

- Payload: 20ft, 28.080 kg / 40ft, 26.780 kg
- Open top containers are provided with tarpaulin, roof bows and TIRcord



20ft & 40ft Open Top Rebuilt

- Payload: 20ft, 21.500 kg / 40ft, 25.000 kg
- Open top containers are provided with a new tarpaulin, roof bows and TIRcord
- Containers have a Lloyds certificate
- Containers can be fitted with a fixed or removable door header



20ft & 40ft Hard Top Original

- Payload: 20ft, 28.080 kg / 40ft, 25.780 kg
- Hard top containers are fitted with a removable roof



20ft & 40ft Hard Top Rebuilt

- Payload: 20ft, 21.500 kg / 40ft 25.000 kg
- Hard top containers are fitted with a removable roof

We offer various container solutions



20ft & 40ft Reefers

- Suitable for storage of food and non-food products
- 24/7 repair service in the Netherlands and Belgium
- Before delivery, these containers are tested (Pre Trip Inspection, machine gets tested for 24 hours to discover any malfunctions)
- Machinery from Carrier and Thermo King
- 40ft Reefers are also available as high cube, 30 cm higher, so you can transport voluminous cargo



20ft & 40ft Platform

- Payload: 20ft, 31.260 kg / 40ft 39.300 kg
- These containers have no end walls



20ft & 40ft Flat Fixed End

- Payload: 20ft, varies from 20.900 to 32.740 kg / 40ft, varies from 29.200 to 39.700 kg
- These containers have fixed end walls



20ft & 40ft Flat Collapsible

- Payload: 20ft, varies from 20.900 to 32.740 kg / 40ft varies from 29.200 to 39.700 kg
- End walls can be collapsed into or onto the floor
- Transportable as a bundle

We offer various container solutions



20ft & 40ft Double Door

- Container doors at both ends make these containers easy accessible from both short sides



20ft Full Side Access

- Easy accessible and closable with doors from the front and side
- Because of the open construction, these containers have thicker floors (250mm)



20ft Bulk Containers

- These containers have a full-width front-discharge hatch, so the bulk freight can be unloaded by means of a tilting chassis



20ft Bulk Containers

- Three man holes in the roof for loading and unloading
- These containers have a steel floor

We offer various container solutions



10ft Offshore Reefer Rebuilt

- Containers are Lloyds certified, MPI tested and provided with approved pad eyes
- Includes: Slings and 9 bullbars (protection for impact)



10ft Offshore Reefer Rebuilt

- In accordance with NOPEGA Standards
- Payload: 8.000 kg
- Provided with Carrier machinery



20ft ISO/DNV 2.7-1 EN12079 Offshore Container

- Production in accordance with DNV 2.7-1 EN12079 rules
- External and internal sizes are equal to a 20ft standard container
- Pad eyes are within ISO standards
- Tested as a standard container on 30.000 kg (payload 27.500 kg)



20ft ISO/DNV 2.7-1 EN12079 Offshore Container

- CARU personnel on site for inspection and control of the whole production process
- Tailor made solutions in any quantity for every customer, with competitive tariffs
- Thanks to the use of high quality steel, construction and welding techniques the payload is 12.000 kg under DNV rules

We offer various container solutions



20ft Tank Containers

- IMO-0 and IMO-1 class tanks are available (if requested, other IMO classifications can be provided)



20ft Tank Containers

- Depending on the IMO classification, the tank containers are suitable for transport and/or storage
- Capacity varies from 14.000 liters to 26.000 liters



20ft Half Height Rebuilt

- Payload: 10.000 kg
- Half height rebuilt containers are Lloyds certified
- Provided with a steel or wooden floor
- Can be supplied with or without tarpaulin, TIRcord and roof bows
- Also available as hard top half height



Pallet Wide

- Available in a 40ft and 45ft version
- Because of the width, suitable to load two, one way pallets next to each other

CARU
containers

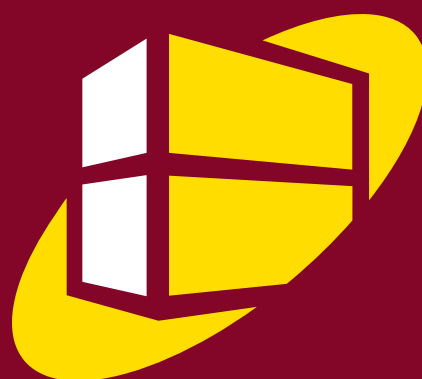

Always a solution!

Locations CARU Group

CARU Containers BV (head office)

Graanweg 11
4782 PP Moerdijk
The Netherlands
Telephone 0031 (0) 168 387 000
Faxnumber 0031 (0) 168 387 008
E-mail info@carucontainers.com

CARU Praha sro

Zápy 238
250 89 Lázně Toušen
Czech Republic
Telephone 0042 (0) 255 717 503
Faxnumber 0042 (0) 255 717 506
E-mail kontejnery@caru.cz

CARU International BV

4 rue Liotard
CH-1202 Geneva
Switzerland
Telephone 0041 (0) 223 454 294
Faxnumber 0041 (0) 223 457 459
E-mail info@caru.ch

CARU France SARL - Dunkerque

2 rue Garibaldi
Zone Industrielle
59760 GRANDE SYNTHE
France
Telephone 00.33.(0)3.28.29.17.99
Fax 00.33.(0)3.28.29.14.85
E-mail info@carucontainers.com

CARU Belgium BVBA

Luithagen - Haven 18
2030 Antwerpen
Belgium
Telephone 0032 (0) 354 005 20
Faxnumber 0032 (0) 354 005 21
E-mail info@carucontainers.com

CARU Thollembeek GmbH

Hanns-Klemm-Strasse 2
D-71157 Hildrizhausen
Germany
Telephone 0049 (0) 7034 27911 0
Faxnumber 0049 (0) 7034 27911 80
E-mail info@thollembeek.de

CARU Containers Inc.

859 Willard Street, 1 Adams Pl
MA 02169 Quincy
United States of America
Telephone 001 617 927 4914
Faxnumber 001 617 927 4915
E-mail boston@carucontainers.com

CARU France SARL - Le Havre

« Le Vaisseau »
120 Boulevard Amiral Mouchez
76087 Le Havre Cedex
France
Telephone 00.33.(0)2 35 24 77 02
Fax 00.33.(0)2 35 26 51 60
Email info@carucontainers.com

www.carucontainers.com

Depots in:

Argentina, Australia, Austria, Belgium, Brasil, Canada, Chili, China, Czech Republic, Denmark, Finland, France, Germany, India, Indonesia, Ireland, Italy, Korea, Malaysia, Netherlands, Peru, Portugal, Russia, Singapore, Slovak Republic, South Africa, Spain, Sweden, Switzerland, Taiwan, Thailand, Turkey, UK, USA



Always a solution!